

## BORA air purification box with 3 activated charcoal filters

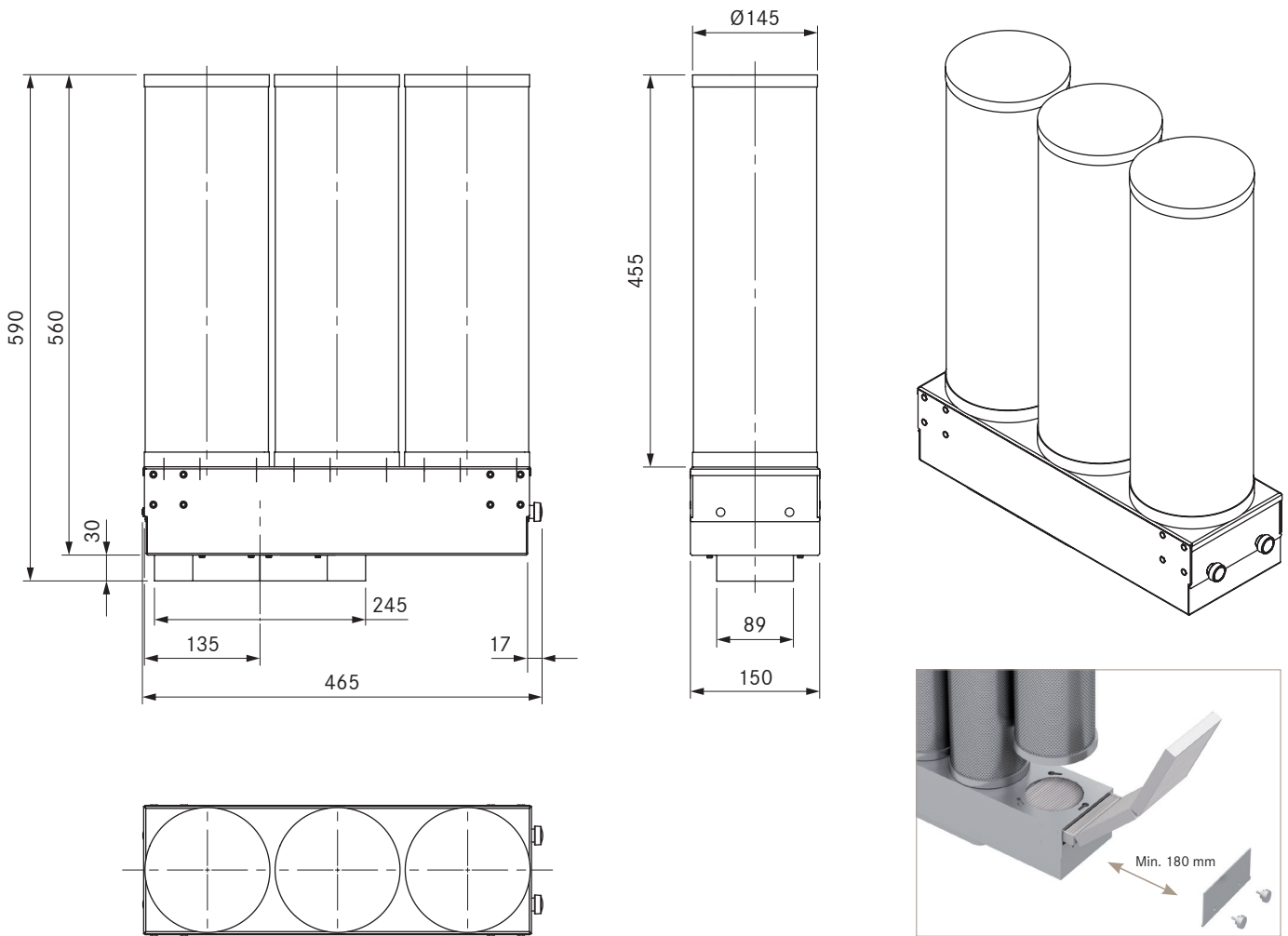

### Technical data

Activated charcoal mass incl. carrier material	8.5 kg
Material filter	Activated charcoal granulate
Housing material	Galvanised sheet steel
Dimensions (WxDxH)	465 x 560 x 150 mm
Shallow duct connection	245 x 89 x 30 mm
Weight (incl. accessories/packaging)	Approx. 11.5 kg
Service life	400 h / 2 years
Duct connection	BORA Ecotube

### Product description

- Odour filter for cleaning the air in domestic kitchens
- Diverse installation options
- Connection to BORA Ecotube 245 x 89 x 30 mm
- Access for maintenance must be considered during planning
- Clearance of at least 2 cm is required to replace the filter cartridges
- Easy filter change
- Ensure a minimum return flow aperture of 500 cm<sup>2</sup> (e.g. plinth overlay or slatted plinth)

### Scope of delivery

- ULB3 air purification box with 3 activated charcoal filters
- 3 x activated charcoal filter cartridges
- Housing plinth
- ULBAS fine filter set
- Fixing screw set
- 2 x angle brackets
- 2 x fastening clips
- Operating and installation instructions

### Accessories

- ULBAS replacement activated charcoal filter set
- ULBRH3 air purification box return hood

